

The Aquifer



Phone: (253) 845-1542 • Fax: (253) 845-4728 • 10408 144th St E, Puyallup, WA 98374

Regular Business Hours:

7:30 AM to 4:00 PM*
Monday – Friday
Closed on Saturday and Sunday.

*If you have an after-hours emergency, please call 253-948-6780 to reach our after-hours technician.

General Manager:
Larry Jones

Board of Directors:
Austin Fisher
Mitchell Hinds
Donald Rose
Scott Williams

Please visit us at
www.firgrove.org for
more information.

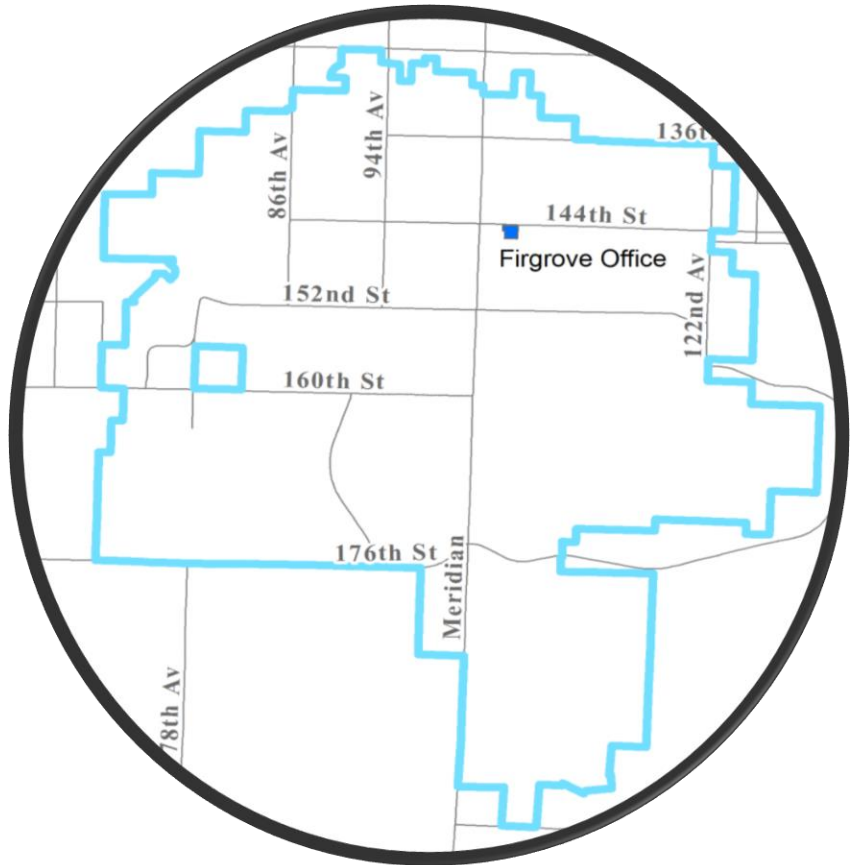

Firgrove's office is located on the East side of Meridian Ave E,
on 144th St E.

Mission Statement

It is the mission of Firgrove Mutual Water Company to provide high quality drinking water and excellent customer service. We will maintain the balance of quality service and cost effectiveness that best benefits our customers. We will be an integral member of our community through positive and supportive actions as its water purveyor. We will be environmentally responsible and responsive to the needs of economic development.

Do You Need a New Year's Resolution?

A quick and easy resolution to make is double checking that your contact information is up to date with your utility companies. This makes it easier for your utilities to contact you in instances of a past due bill, or during times of emergency.

Please call or email Firgrove at 253-845-1542 or info@firgrove.org to update your account information, if it has recently changed.

Maintaining Your Service Lines

Underground pipes can break down and crack over time. If you live in an older home and the service lines have never been replaced, it is always a good idea to keep an eye out for potential leaks. While digging up all the service lines every so often is not a feasible option, you can still look to see if there are leaks in your lines by turning off all running water and glancing at your meter. If the meter is spinning that means that you have a leak and action will need to be taken.



Fun Fact:

*Only 3.5% of water on Earth is fresh.
Over 68% of that fresh water is
trapped in ice, so be sure to
conserve where you can!*

It's Getting Cold Outside

This means that it is time to prepare your household for the chillier months. Cold weather can cause cracks and breaks in water lines. It is important to wrap or cover water spigots and be sure to locate the shut off valve in your home if it has one. If your home does not have its own shut off valve you can call the Firgrove office during business hours, or the after-hours number if the office is closed, and a technician will arrive shortly to turn your water off at the meter so a repair can be made.

It is important to prepare yourself and your family for instances of outages, whether that be water, gas, or power. Making sure that you have bottled water, flashlights, a first aid kit, canned foods, and candles ready can be helpful. If you have run out of stored water and tap water is not available, there are a few hidden sources that can be found throughout your home.

- Water can be drained from the pipes in the home by opening a faucet at the highest point of your home and opening a faucet at the lowest point.
- Water stored as ice in bags, refrigerators, or ice cube trays can be melted.

Do not use water from toilet tanks, radiators, waterbeds, swimming pools, or hot tubs.

Firgrove Holiday Closures:

Thanksgiving – November 25th & 26th

Christmas – December 24th

A Word on the Washington State Utility Proclamation **Expiration**

First and foremost, we hope that you and your families have stayed healthy and safe through this most unusual time. Beyond the health aspects of this pandemic, all individuals, families, and businesses have been impacted by it. These impacts have been recognized by state and local governments and providers of essential services, including Firgrove Mutual Water Company (Firgrove) as a water utility company.

On February 29th, 2020, Governor Inslee proclaimed a State of Emergency for all counties throughout the State. To further help address the impacts of the pandemic, on March 18th, 2020, Governor Inslee issued proclamation 20-23 which among other actions, directed all utilities in the State to: 1) avoid disconnection of services due to non-payment during the statewide emergency declaration, 2) waive late fees, 3) use payment plans to address customer outstanding balances, 4) employ internal employee safety measures, and 5) close facilities to the public. This proclamation has now been extended a sixth time with its expiration scheduled for October 2021.

With the expiration of Governor Inslee's proclamation, Firgrove will begin reinstating late fees and disconnection for nonpayment. If you are a Firgrove customer who has been affected by the pandemic and have fallen past due on your bill, please visit www.firgrove.org/forms.php for a list of assistance agencies. You can also contact the Firgrove office at 253-845-1542 or info@firgrove.org to initiate an extended payment plan. Firgrove's extended payment plan will allow customers to pay off the high balances accrued during the pandemic over an 18-month period. Please contact the Firgrove office as soon as possible if you require assistance.



Firgrove's Payment Options:

A frequently asked question is how one might go about paying their water bill. Firgrove has begun taking card payments over the phone. In addition to this, you can pay with cash, check, card, or money order in the lobby or 24-hour drop box. You can also mail payment, remit payment using your bank's online bill pay service, or you can sign up for auto pay. If you need assistance paying your bill, a list of assistance agencies can be found at: <https://www.firgrove.org/forms/000127.pdf>

If you have any questions regarding these payment options, please give the Firgrove office a call.

Fun Stuff for the Kids

Fun Stuff for the Kids

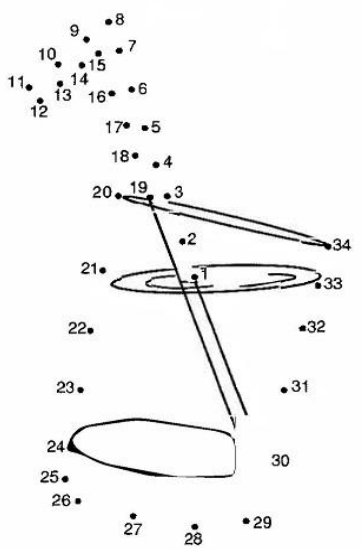
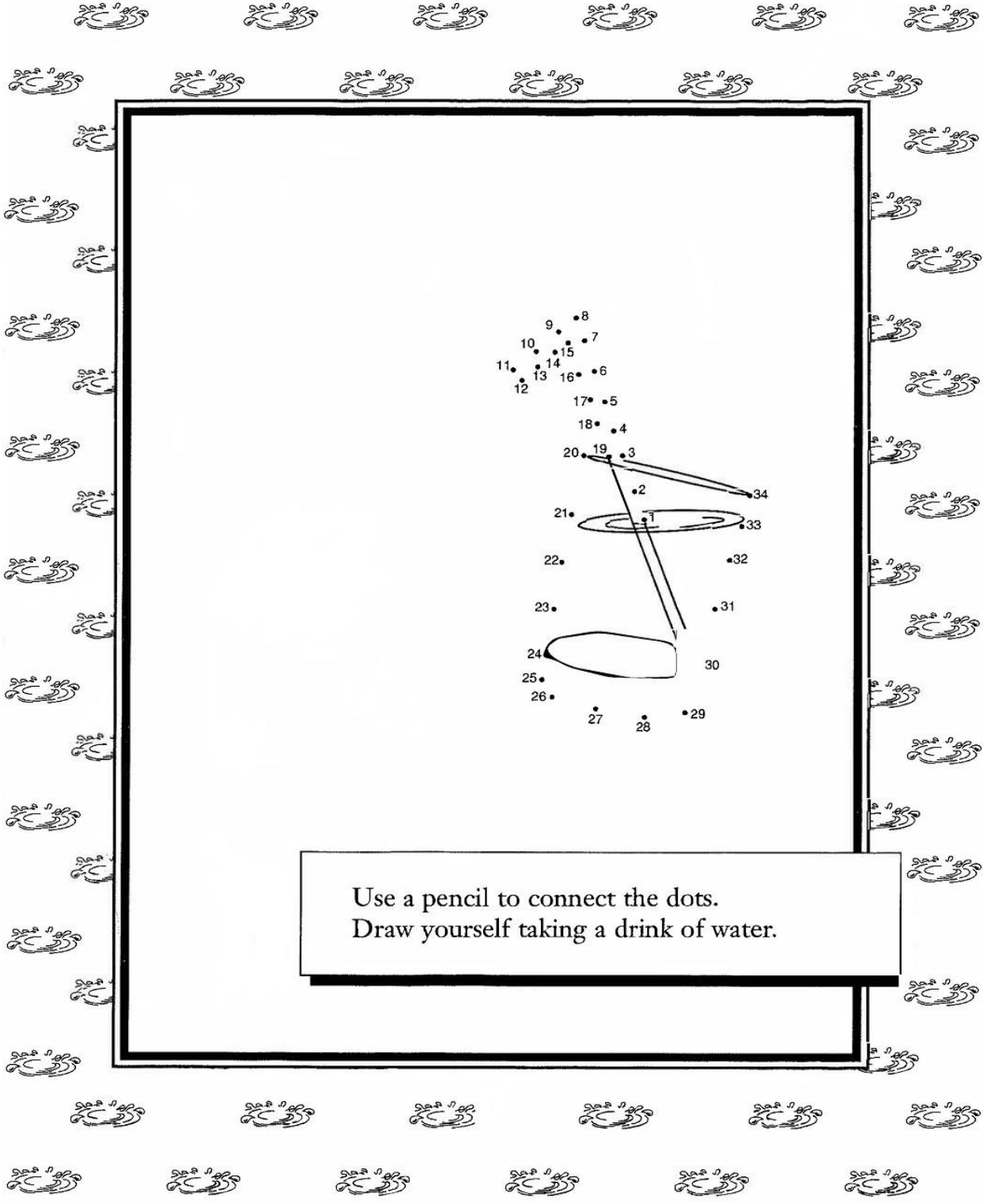

Use a pencil to connect the dots.
Draw yourself taking a drink of water.